

## Direct-acting 3/2-way plunger valve

- Direct-acting, compact valve with diameter of up to DN 2.5
- Vibration-proof, bolted coil system
- Banjo threaded connection for direct mounting on pneumatic valves
- Service-friendly manual override
- Energy-saving impulse versions

Type 6014 can be combined with...



**Type 2508**  
Cable Plug



**Type 6014**  
Multiple manifold  
(e.g. 6-fold)



**Type 2511**  
Cable plug

Valve 6014 is a direct-acting plunger valve. The stopper and plunger guiding tube are welded together to enhance pressure resistance and leak-tightness. Various seal material combinations are available depending on the application. A Bürkert-specific flange design (SFB) enables space-saving arrangement of valves on a manifold. The coils are moulded with polyamide or with chemically resistant epoxy. Pulse coils are available for the reduction of electrical power consumption during operation. Optional manual actuation enables quick commissioning and easy maintenance. In combination with a plug in accordance with DIN EN 17301-803 Form A, the valves satisfy protection class IP65. Stainless steel valves satisfy NEMA 4X.

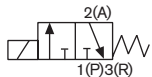

3/2-way valve NC,  
outlet 2 relieved

### Circuit function C



3/2-way valve NO, outlet  
2 normally pressurized

### Circuit function D

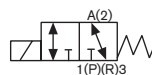

3/2-way,  
universal valve

### Circuit function T

Technical data	
<b>Body material</b>	Brass or stainless steel, polyamide (sub-base)
<b>Seal material</b>	FKM (EPDM on request)
<b>Medium</b>	Neutral gases and fluids (e.g. compressed air, town gas, natural gas, water, hydraulic oil, petrol). Suitable for technical vacuum
<b>Medium temperature</b> Polyamide coil (FKM seal)	-10° to +100°C (PA coil) to 120°C Epoxy coil
<b>Ambient temperature</b>	Max. +55°C
<b>Viscosity</b>	Max. 21 mm <sup>2</sup> /s
<b>Port connection</b>	G 1/8, G 1/4, sub-base (SFB)
<b>Operating voltage</b>	24 V DC, 24 V/50 Hz, 230 V/50 Hz (other voltages on request)
<b>Voltage tolerance</b>	±10%
<b>Duty cycle / single valve</b> Assembly	100% continuous rating Intermittent operation 60% (30 min) or with 5 W coil (on request)
<b>Electrical connection</b>	DIN EN 175301-803 Form A for Cable Plug, Type 2508 (see Ordering chart for accessories) ATEX/IECEX version with 3 m moulded cable
<b>Installation</b>	As required, preferably with actuator upright
<b>Protection class</b>	IP65 with Cable Plug
<b>Coil insulation class</b>	Polyamide class B (Epoxy class H on request)
<b>Coil material</b>	Polyamide (Epoxy on request)
<b>Orifice</b>	DN 1.5 - 2.5

## Technical data

### Power consumption

Orifice [mm] [mm]	Power consumption		
	Inrush AC [VA]	Hold AC (hot coil) [VA]    [W]	DC hot / cold coil [W]
1.5-2.5	24	17    8	8 / 9

### Response times

Orifice [mm]	Response times AC and DC	
	Opening [ms]	Closing [ms]
1.5	10-15	15-20
2.0	10-15	15-20
2.5	15-20	10-22

#### Response times [ms]:

Measured at valve outlet at 6 bar and +20°C.

Opening: Pressure build-up 0 - 90%, to

Closing: Pressure relief 100 to 10%

## Materials

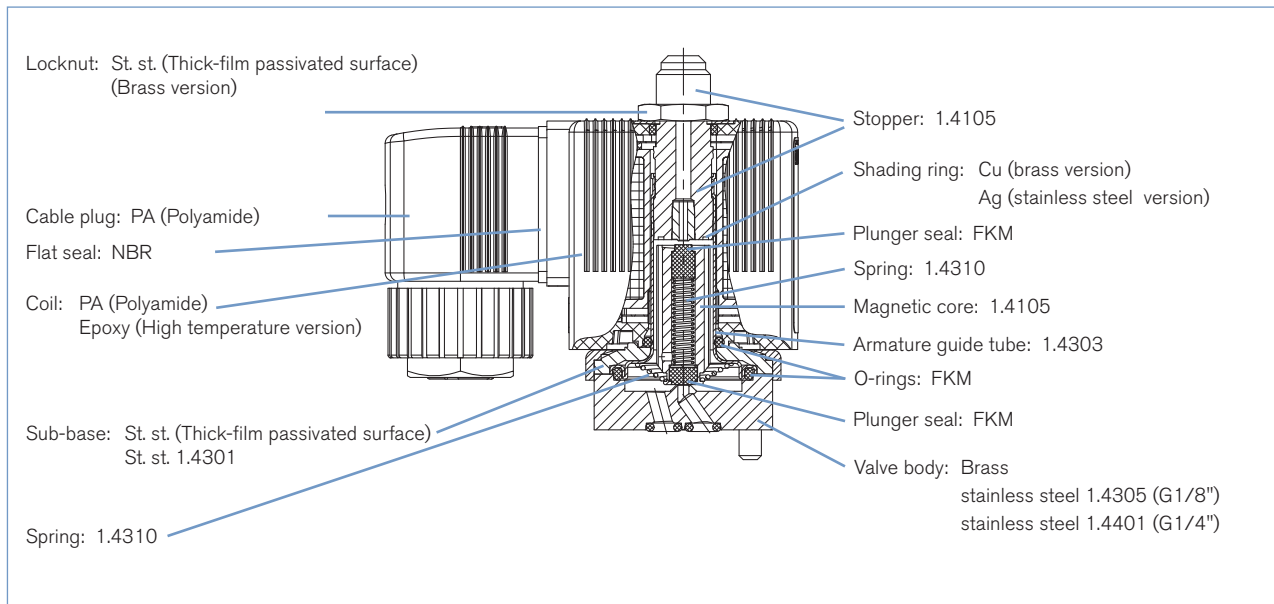

Dimensions [mm]

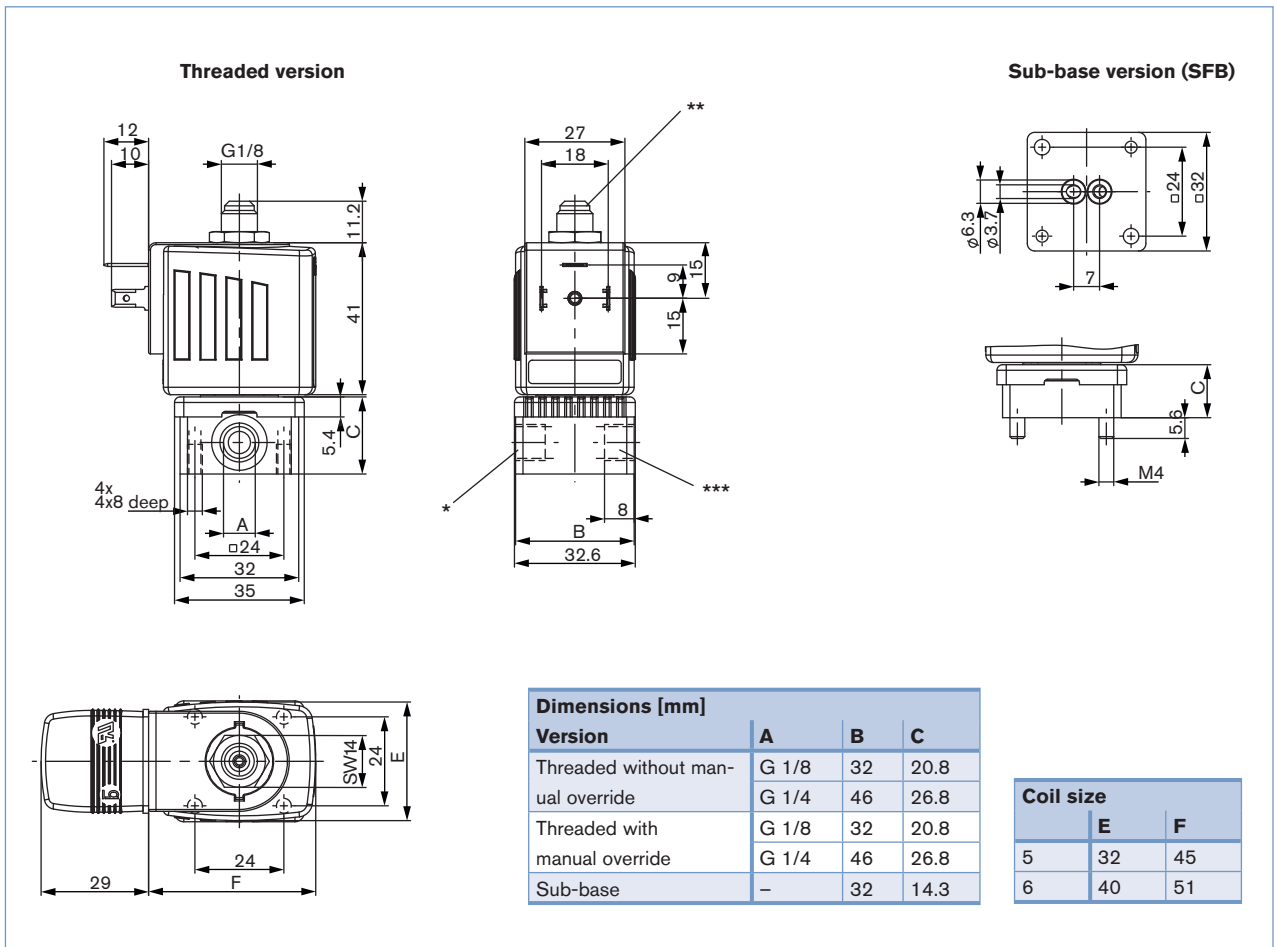

Utilisation in another circuit function

Valves with circuit functions (WW) C, D and T are fitted with different springs. If used in some other circuit function, the permissible operating pressure may change (see table below).

Valve Version Basic version		Max. operating pressure [bar] for valve application in circuit function				
DN	Circuit function	A	B	C	D	T
1.5	C	16	22	16	2	2
	D	2	2.5	2	16	2
	T	10	16	10	6	6
2.0	C	10	14	10	1	1
	D	1	1.5	1	10	1
	T	6	10	6	4	4
2.5	C	6	9	6	0.7	0.7
	D	0.7	1	0.7	6	0.7
	T	3.5	6	3.5	2.5	2.5

Connections

For the positions marked with \*, \*\* or \*\*\* in the drawing, the connections are marked with the letters shown in the table above, depending on the circuit function. Unused connections in circuit functions A or B will be closed off with a blanking plug or cap nut.

Circuit function	Connection Type		
	*	**	***
A	P	blank off	A
B	blank off	B	P
C	P	R	A
D	R	P	B
T	P	R	A

• see drawing on page 7

## Ordering chart for valves (other versions on request)

## 6014 Threaded valves with FKM seal, (class B)

Delivered without cable plug (see accessories)

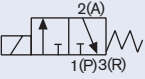
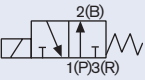
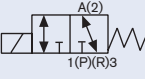
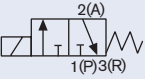
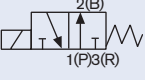
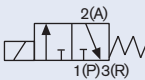
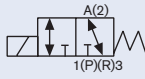
Circuit function	Orifice [mm]	Port connection	Kv value water [m <sup>3</sup> /h] <sup>1)</sup>	Pressure range [bar] <sup>2)</sup>	Effective coil power [W]	Item no. per voltage / frequency		
						024/DC	024/50	230/50
<b>Brass body</b>								
<b>C</b> 3/2-way valve NC 	1.5	G 1/8	0.07	0 - 16	8	125 329	125 331	125 332
	2.0	G 1/8	0.11	0 - 10	8	125 333	125 334	125 336
		G 1/4	0.11	0 - 10	8	125 348	126 138	126 140
	2.5	G 1/8	0.16	0 - 6	8	125 341	125 340	125 342
		G 1/4	0.16	0 - 6	8	126 142	126 143	126 145
<b>D</b> 3/2 way valve, NO 	1.5	G 1/8	0.07	0 - 16	8	126 195	126 196	125 355
	2.0	G 1/8	0.11	0 - 10	8	125 357	125 358	125 360
		G 1/4	0.11	0 - 10	8	126 198	126 199	126 201
	2.5	G 1/8	0.16	0 - 6	8	125 363	126 202	126 204
		G 1/4	0.16	0 - 6	8	126 205	126 206	126 208
<b>T</b> 3/2-way Universal valve 	1.5	G 1/8	0.07	0 - 7	8	126 150	126 151	126 153
<b>with manual override</b>								
<b>C</b> 3/2-way valve NC 	2.0	G 1/8	0.11	0 - 10	8	125 337	125 338	125 339
		G 1/4	0.11	0 - 10	8	125 349	126 147	126 149
<b>D</b> 3/2 way valve, NO 	2.0	G 1/8	0.11	0 - 10	8	126 209	125 361	126 211
		G 1/4	0.11	0 - 10	8	126 212	126 213	126 215
<b>Stainless steel body</b>								
<b>C</b> 3/2-way valve NC 	1.5	G 1/8	0.07	0 - 16	8	126 216	126 217	126 219
	2.0	G 1/8	0.11	0 - 10	8	126 220	126 221	126 223
		G 1/4	0.11	0 - 10	8	126 224	126 225	126 227
<b>T</b> 3/2-way, universal valve 	1.5	G 1/8	0.07	0 - 7	8	126 228	126 229	126 231

<sup>1)</sup> Measured at +20 °C, 1 bar<sup>2)</sup> pressure difference<sup>2)</sup> Measured as overpressure to the atmospheric pressure

## Ordering chart for valves (other versions on request)

## 6014 Valves with FKM seal and sub-base body (SFB), (class B)

Delivered without cable plug (see accessories)

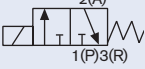
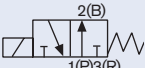
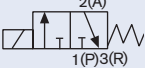
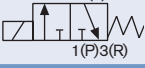
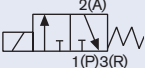
Circuit function	Orifice [mm]	Kv value water [m <sup>3</sup> /h] <sup>1)</sup>	Pressure range [bar] <sup>2)</sup>	Effective coil power [W]	Item no. per voltage / frequency		
					024/DC	024/50	230/50
<b>Brass body</b>							
<b>C</b> 3/2-way valve NC 	1.5	0.07	0 - 16	8	126 154	126 155	125 366
	2.0	0.11	0 - 10	8	125 367	125 368	125 370
<b>D</b> 3/2 way valve, NO 	2.0	0.11	0 - 10	8	126 161	126 162	125 383
<b>with manual override</b>							
<b>C</b> 3/2-way valve NC 	1.5	0.07	0 - 10	5	126 403	126 404	126 406
	1.5	0.07	0 - 16	8	126 157	126 158	126 160
	2.0	0.11	0 - 6	5	126 407	126 408	126 410
	2.0	0.11	0 - 10	8	125 371	125 372	125 374
<b>Polyamide body material</b>							
<b>C</b> 3/2-way valve NC 	1.5	0.07	0 - 10	5	126 390	126 391	126 393
<b>with manual override</b>							
<b>C</b> 3/2-way valve NC 	1.5	0.07	0 - 10	5	126 396	126 397	126 399

<sup>1)</sup> Measured at +20 °C, 1 bar <sup>2)</sup> pressure difference<sup>2)</sup> Measured as overpressure to the atmospheric pressure

Ordering chart for valves, impulse version (other versions on request)

6014 Impuls valve with FKM seal material and brass body (class H)

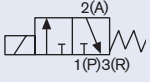
Circuit function	Port connection		Orifice [mm]	Kv value water [m <sup>3</sup> /h] <sup>1)</sup>	Pressure range [bar] <sup>2)</sup>	Power consumption DC (hot/cold coil) [W]	Item no. per voltage [V/]	
							012/DC	024/DC
<b>C</b> 3/2-way valve, output 2 exhausted 	<b>Brass body</b>							
	Threaded port	G 1/8	1.5	0.07	0-16	7	209 280	209 284
				2.0	0.11	0-10	7	209 281
	Sub-base {SFB}			1.5	0.07	0-16	7	209 278
			2.0	0.11	0-10	7	209 279	209 283

<sup>1)</sup> Measured at +20 °C, 1 bar<sup>2)</sup> pressure difference

<sup>2)</sup> Measured as overpressure to the atmospheric pressure

Activation of the impulse version with inverse polarity operation

The polarity is labelled on the valve	Specifications	Terminal connections
- switch ON +	valve will be opened	(+) on terminal 2 and (-) on terminal 1 (see below)
+ switch OFF -	valve will be closed	(+) on terminal 1 and (-) on terminal 2 (see below)

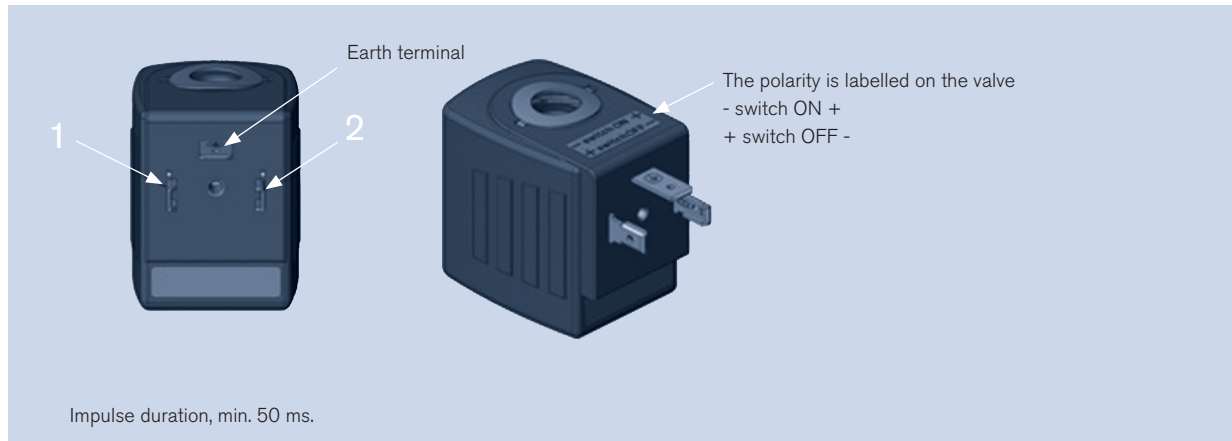

**Note:** Only cable plug without circuitry should be used together with impulse version!

Materials for ATEX/IECEX m

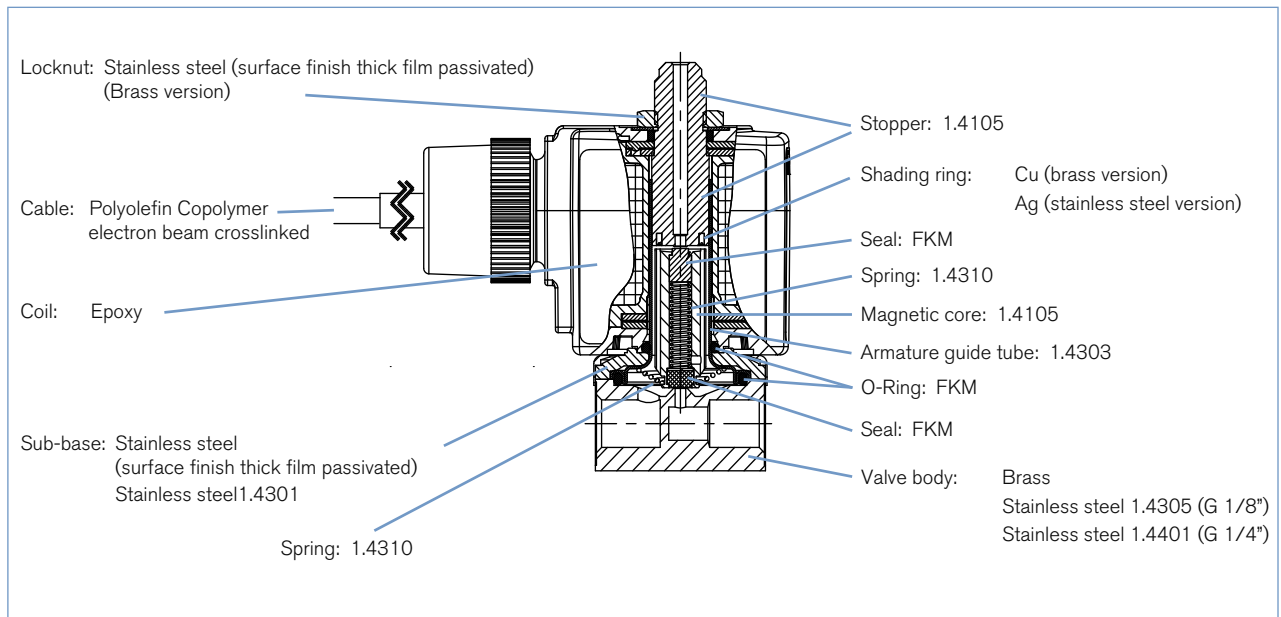

Dimensions for ATEX/IECEX m [mm]

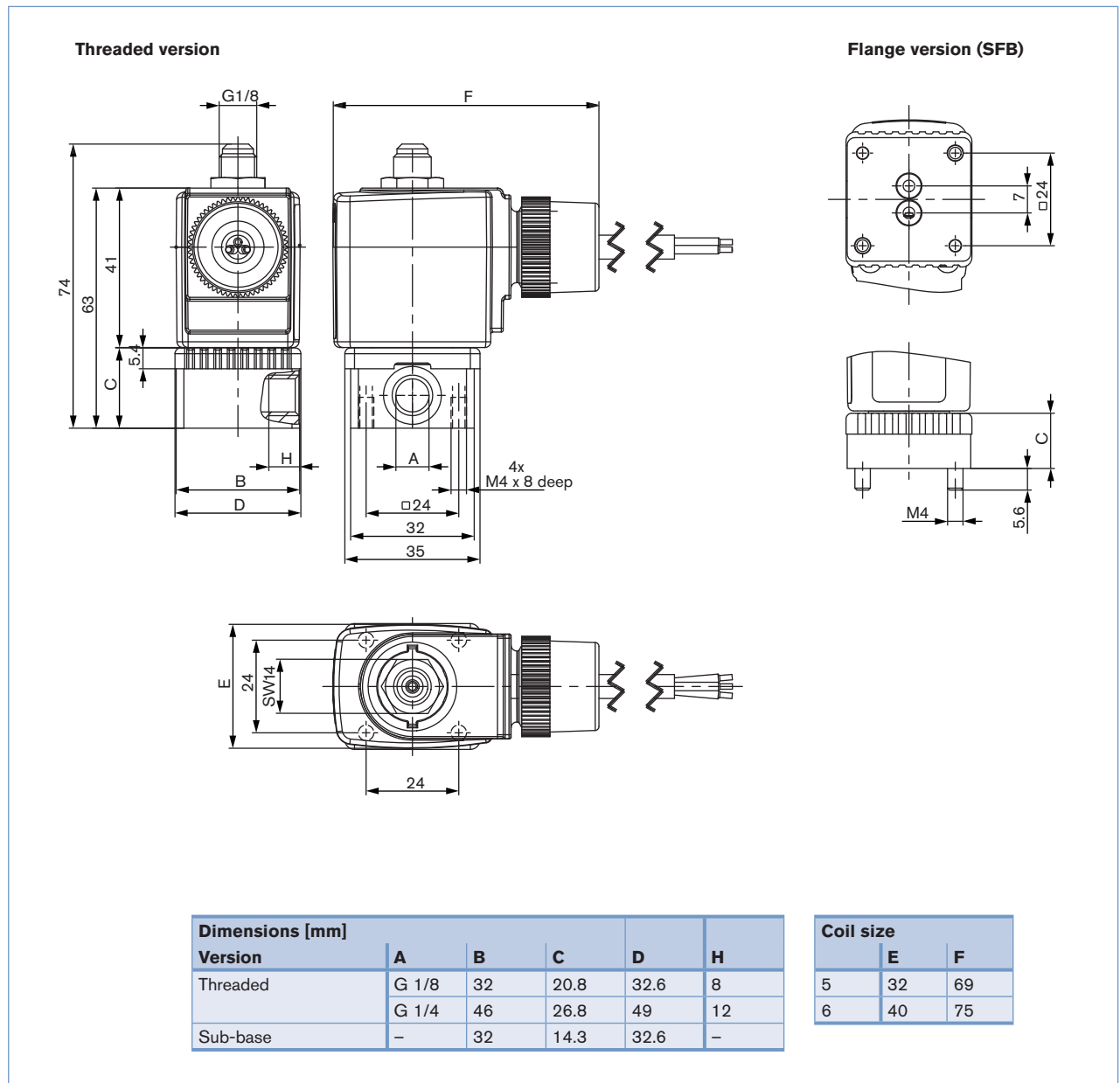



## Ordering chart for Ex m valves

6014 valve, Ex m II T4, with FKM seal material and sub-base (SFB) conneciton with 3m moulded cable approved for block mounting, ambient temperature from -10°C to +40°C

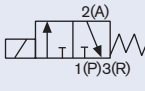
Circuit function	Orifice [mm]	Port connection	Kv-value water [m³/h]	Pressure range [bar]	Body material	Effective coil power [W]	Voltage/frequency [V/Hz]	Item no. with manual override
	1.5	sub-base (SFB)	0.07	0-10	PA	7	024/UC	278 651
					Brass	7	230/UC	278 653
	2.0	sub-base (SFB)	0.11	0-6	Brass	7	024/UC	278 655
					Brass	7	230/UC	278 656
						024/UC	278 658	
							230/UC	278 659

6014 valve, Ex m II T4, with FKM seal material and threaded conneciton with 3m moulded cable approved for single mounting, ambient temperature from -10°C to +55°C

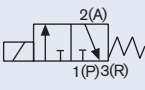
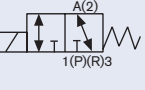
Circuit function	Orifice [mm]	Port connection	Kv-value water [m³/h]	Pressure range [bar]	Body material	Effective coil power [W]	Voltage/frequency [V/Hz]	Item no. without manual override	Item no. with manual override
	2.0	G 1/8	0.11	0-10	Brass	9	024/UC	278 637	278 645
					Brass	9	230/UC	278 638	278 646
		Stainless steel	9	024/UC	278 660	x			
		Stainless steel	9	230/UC	278 661	x			
		Brass	9	024/UC	278 639	278 647			
		Brass	9	230/UC	278 641	278 649			
	2.5	G 1/8	0.16	0-6	Brass	9	024/UC	x	x
					Brass	9	230/UC	x	x
		G 1/4	0.16	0-6	Brass	9	024/UC	278 643	278 673
					Brass	9	230/UC	278 644	x
	1.5	G 1/8	0.07	0-7	Brass	9	024/UC	278 650	x
					Brass	9	230/UC	x	x
		Stainless steel	9	024/UC	278 664	x			
		Stainless steel	9	230/UC	278 665	x			
	G 1/4	0.07	0-7	Brass	9	024/UC	x	x	
				Brass	9	230/UC	x	x	
		Stainless steel	9	024/UC	278 666	x			
		Stainless steel	9	230/UC	x	x			

x on request

The maximum fluid temperature must not in any case exceed the permissible temperature class (T4 135 °C, 100 °C T5, T6 85 °C), of minus 5 K.

## Explosion-proof approvals

ATEX: PTB 14 ATEX 2023 X

II 2G Ex mb IIC T4 Gb

II 2D Ex mb IIIC T135 °C Db

IECEX: IECEX PTB 14.0049 X

Ex mb IIC T4 Gb

Ex mb IIIC T135 °C Db

### i Further versions on request



#### Materials

Epoxy coil according to Form A  
Seal material EPDM



#### Voltage

Non-standard voltages



#### Port connection

With banjo nut



#### Approvals

ATEX, UL, CSA



#### Additional

Orifice: 1.2mm, 3.0mm

## Materialangaben für ATEX/IECEx ia

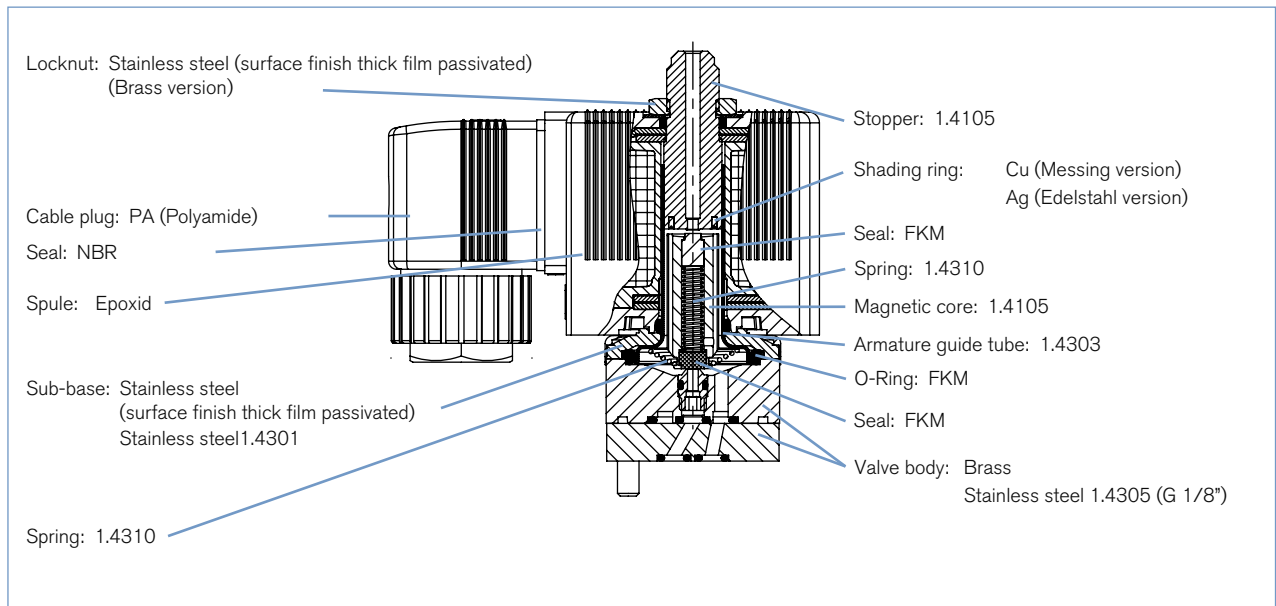

## Abmessungen für ATEX/IECEX ia [mm]

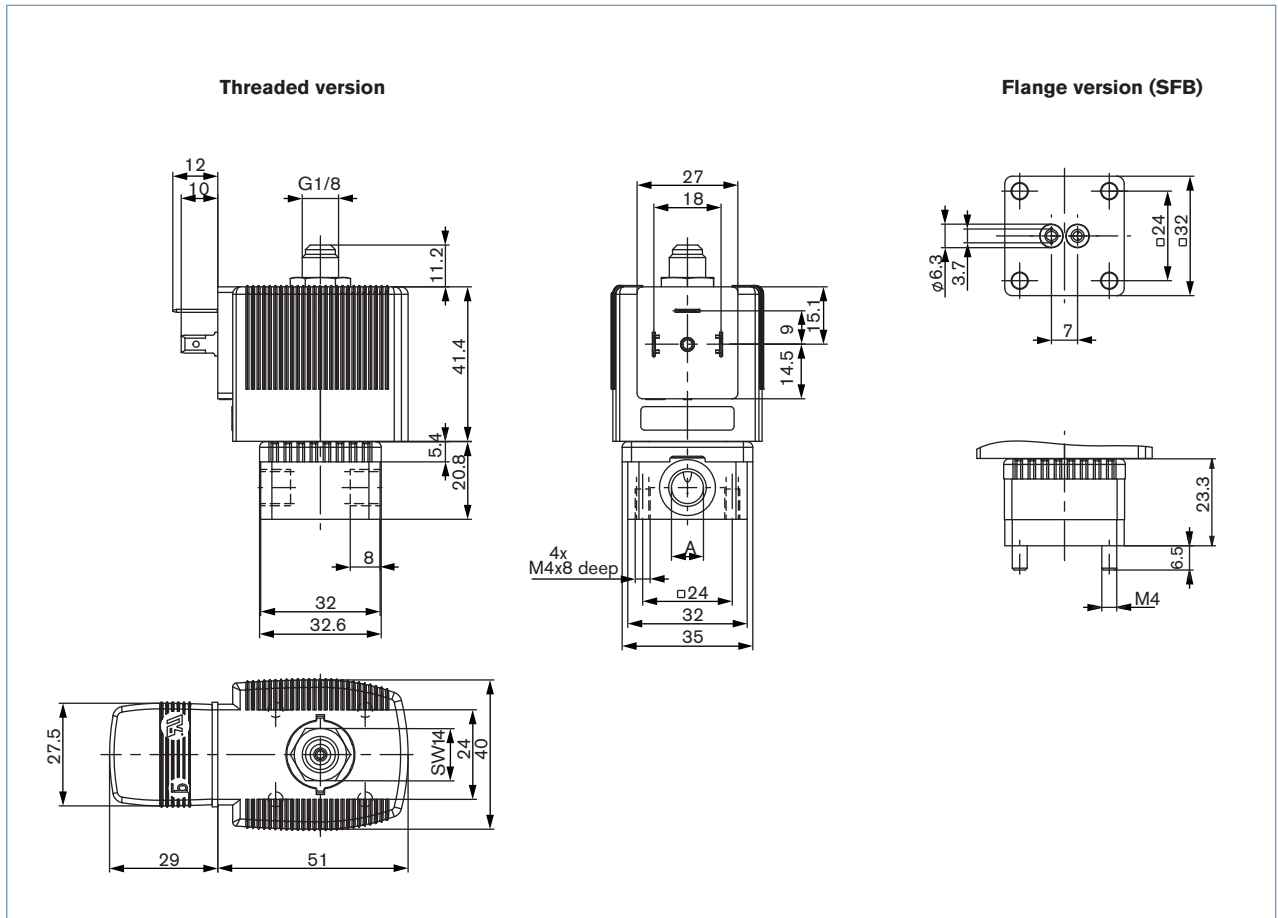

## Electrical data

**Type of protection** EEx ia IIC T6 acc. to PTB-No. Ex-96.D.2010

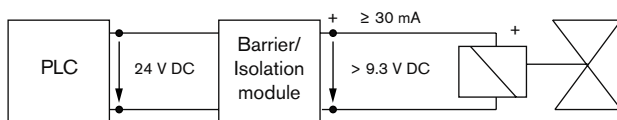

**Note:** The valve is designed to operate on **24 V DC** outputs through an intermediary intrinsically safe apparatus (isolating block or barrier)..

Function values for switching valve	Max. allowable values acc. to the certificate of conformity	
	at +20 °C	at +55 °C
Minimum switching current	30 mA	30 mA
Nominal resistance coil	310 $\Omega$	360 $\Omega$
Minimum terminal voltage	9.3 V	10.8 V

Function values for switching valve	
U <sub>i</sub>	28 V
I <sub>i</sub>	120 mA
P <sub>i</sub>	1,1 W
Ambient temperature	+60 °C at T6 +75 °C at T5

## Technical data - ATEX/IECEX -ia

### Response times

Response times	
Opening [ms]	Closing [ms]
20	22

#### Response times [ms]:

Measured at valve outlet at 6 bar and +20°C

Opening: Pressure build-up 0 to 90%,

Closing: Pressure drop 100 to 10%

## Ordering chart - ATEX/IECEX -ia

6014 valve; Ex ia II T6 with FKM seal material only for approved single mounting, cable plug acc. to DINEN 175301-803 Form A, ambient temperature from -10°C to 60°C for T6, -10 to -75°C for T5

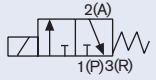
Circuit function	Orifice [mm]	QN-value air [l/min]	Pressure range [bar]	Body material	Port connection	Item no. with manual override
	0.9	30	Vac. to 10	Stainless steel	Bürkert sub-base (SFB)	144 540
					G 1/8	147 226
				Brass	Bürkert-sub-base (SFB)	147 227
					G 1/8	146 214

The maximum fluid temperature must not in any case exceed the permissible temperature class (T4 135 °C, 100 °C T5, T6 85 °C), of minus 5 K.

### Explosion-proof approvals

ATEX: PTB 01 ATEX 2101 0102

II 2G Ex i IIC T6 Gb

II 2D Ex i IIIC T85 °C Db

PTB IECEX12.0040

Ex ia IIC T6 Gb

Ex ia IIC T80°C Db

## Ordering chart for accessories

### Cable plug Type 2508 acc. to DIN EN 175301-803 Form A

	Circuit	Voltage / frequency	Item no.
	without circuitry	0 - 250 V	438 574

## Ordering chart for Manifolds

Accessory parts	Features				Item no.
Single manifold	in aluminium black anodized				005 020
Multiple manifold	in aluminium	Hole spacing A [mm]	Total length B [mm]	Hole spacing C [mm]	
	2 valves	57	65	–	005 023
	3 valves	90	98	–	005 286
	4 valves	123	131	–	005 287
	5 valves	156	164	57	005 035
	6 valves	189	197	57	005 038
	8 valves	255	263	90	005 386
	10 valves	321	329	90	005 764
Covering plate	with plugs and O-ring, for closing off unused valve positions				005 630

Manifolds in Brass or stainless steel on request

**Manifold mounting**

With manifold mounting, please comply with the permissible duty cycle (5 W models with 100% continuous rating or 8 W model with 60% duty cycle). The pressure port for the manifold is designated with P (R), and the outlet port with A (B). Only connect together ports with the same designation.

2/2-way valves of Type 6013 can be operated together on a manifold with 3/2-way valves of Type 6014, circuit function C (not D or T!) if the operating pressures agree according to the rating plates. The manifolds can also be expanded if the valve functions are taken into consideration.

**Caution!** Unused, open valve ports must be closed off with covering plates (see ordering chart above).

## Ordering chart for accessory

## Cable plug Type 2508 according to DIN EN 175301-803 Form A

	Circuitry	Voltage/ Frequency	Item no.
	None (standard)	0 - 250 V AC/DC	008 376
	with LED	12 - 24 V AC/DC	008 360
	with LED and varistor	12 - 24 V AC/DC	008 367
	with LED and varistor	200- 240V	008 369
	with inverter <sup>1)</sup>	24V DC	on request
	further versions see datasheet Type 2508		

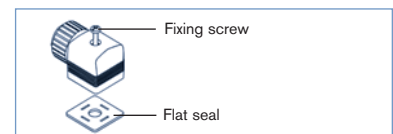

The delivery of a cable plug includes the flat seal and the fixing screw. For other cable plug versions, see separate datasheet Type 2508. Click on the box "More info." and you will come to our website for this product where you can download the datasheet.

**More info.**

<sup>1)</sup> The inverter plug includes an electronic which is specially adapted for an electrical control with 3 wires  
Input 3 wire technology, common "-" polarity, two split "+" polarity.  
Output suitable for impulse model for Type 6013/6014

To find your nearest Bürkert facility, click on the orange box → [www.burkert.com](http://www.burkert.com)

In case of special application conditions,  
please consult for advice.

Subject to alterations  
© Christian Bürkert GmbH & Co. KG

1503/6\_EU-en\_00895091